

Instructions for Assembly and Installation of Ball Valves in accordance with ATEX Directive 2014/34/EU

General information

These instructions supplement the operating and maintenance instructions for manually operated ball valves and specifically point out the assembly steps to be observed in the assembly and installation in accordance with ATEX Directive 2014/34/EU.

Non-compliance with the instructions and provisions listed in this manual may pose risks, which would render the manufacturer's warranty null and void. Should you have any questions, please do not hesitate to get in touch with our project team.

These instructions apply to ball valves of types AF90D, AF94D, AF95D, 80D, as well as all types of series A20D, AF20D, and the respective stem extensions of types 1621D and 1624.

The ball valves are category 2GD devices.

These can be used in accordance with EN 1127-1:1997, EN 13463-1:2001 and EN 13463-5:2002 as follows:

- For gases, mists and vapors in zone 1 and zone 2, as well as the IIA and IIB gas groups within the range of the T1 to T6 temperature classes determined by the medium temperature.
- Without a PVC handle (bare metal handle), the ball valves may be used in zone 1 and zone 2 and in the IIC gas group within the range of the T1 to T6 temperature classes determined by the medium temperature.
- For dusts in zone 21 and zone 22, as well as dust atmospheres with an ignition energy greater than 3 mJ within the range of the surface temperatures determined by the medium temperature.
(The ignition energy is the energy that leads to an explosion of the dust atmosphere)

The permissible ambient temperature ranges between -20°C and $+60^{\circ}\text{C}$.

Antistatic device

Two antistatic devices, consisting of spring-cushioned metal balls in the stem, guarantee the ATEX conformity of the ball valves fitted with a PTFE stem packing. In the Firesafe version with a graphite packing, the function of the antistatic device between stem and housing can be taken over by the graphite packing. The proper function must be ensured and checked, i.e. both antistatic balls (between the ball and the stem and between the housing and the stem) must be present and spring-cushioned on the stem.

Please ensure that the 'antistatic device' is not damaged when installing the stem in the housing.

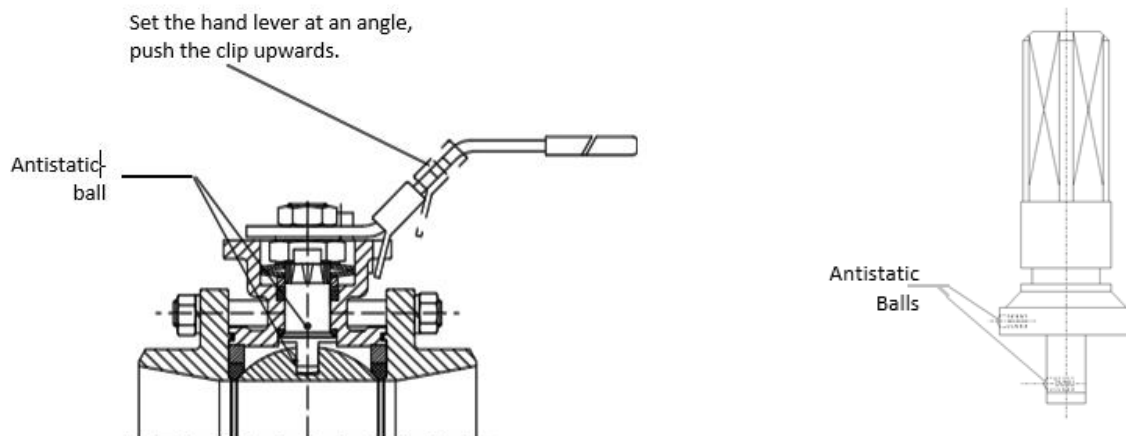

...ATEX Instructions for BV continued...

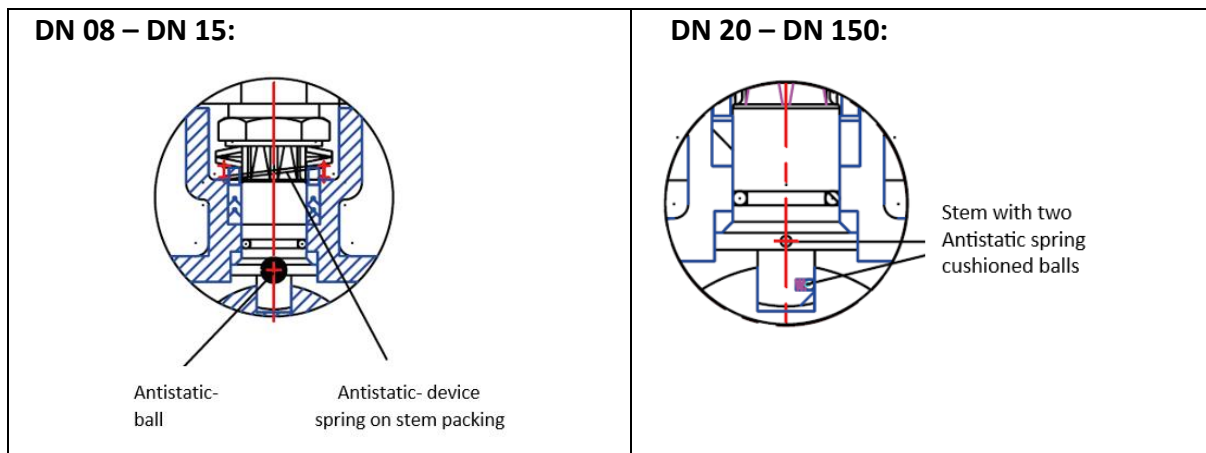

Equipotential bonding check

Once the ball valve has been installed, please check the equipotential bonding function between the switching ball and the ball valve housing using an ohmmeter:

Ensure that neither the hand lever stopper nor the hand lever interlock come into contact with the housing; the locking clip should be pulled upwards and the ball valve should be brought into a half-open position. The ohmmeter is now connected

1. between the **stem** and the housing, as well as
2. between the switching **ball** and the housing, in order to measure electrical continuity if the antistatic devices are functioning properly.
3. The measured resistances may not exceed 1 megohm (MΩ)

Equipotential bonding between the ball valve and the pipeline system

Please note that the ball valve must now be integrated into the equipotential bonding of the entire pipeline system. This is done by welding or screwing in the connections/ends of the 3-piece ball valve or by flanging the flanged ball valve between the piping flanges.

The operator is responsible for ensuring proper execution. Equipotential bonding must be ensured when the ball valve is screwed in place. If the threads are sealed with a Teflon®tape, an electrically-conductive connection must be established between the ball valve housing and the pipeline as a safety precaution.

File: \\MarketingIntern\TECHN.UNTERLAGEN\ZT_Kugelhähne\A20D\ATEX_Anleitung_KH_012021_rev1\MUS_20.01.2021