



ITIS B.V.
 Daniëlsweg 6
 NL-4451 HP Heinkenszand
 T + 31 113 568515
 info@itis-nl.com
 www.itis-nl.com

ITIS Certificate
 201500169-C005 rev2



Industrie Service

API607 AND ISO 10497 FIRE TEST QUALIFICATION CERTIFICATE

This certificate is to certify that the valve below has been tested in accordance with, and meets all requirements stated in API Standard 607, sixth edition September 2010; Fire test for quarter turn valves and valves with non metallic seats, and ISO 10497 third edition 2010-02-15 Testing of valves - Fire- type testing requirements

Test valve details

Manufacturer : Zuercher Technik AG
 Address : Neumattstrasse 6, ch – 4450, Sissach, Switzerland
 Nominal size : DN50 – 2”
 Pressure rating : PN40
 Flow direction : Bi- directional
 Type : Floating Ball valve, Series AF90D
 Weight : 10.4kg
 Drawing number : 1602231.03 date: 01-02-2016
 Body material : 1.0619/A216 WCB
 Body gasket : Graphite
 Stud bolt/Nut material : A2-70/A2-70
 Ball material : 1.4401/316
 Seat material : RPTFE
 Stem material : 1.4401/316
 Stem seal material : Graphite
 Identification No. : 00169005 (by ITIS)
 Markings on valve : Body material, heat no. and Serial number on valve body
 Gearbox : n.a.

Scope of other sizes, weight, pressures and materials qualified by this test.

Tested valve	7.3 Nominal Size	7.4 Pressure rating	7.1 d (e) Weight
NPS2 class 300 DN50	NPS2 and below, 2½, 3 and 4 DN50 and below, 65, 80 and 100	Class 300; 400 and 600 PN40, PN63, and PN100	AF90D and valves with a mass >75%

For material qualification see paragraph 7.2 in report mentioned below.

This certificate is only valid in conjunction with the full ITIS BV test report number 201500169-R005 rev2

Name operator (ITIS)

<input checked="" type="checkbox"/> TESTED
<input type="checkbox"/> REVIEW
<input type="checkbox"/> WITNESSED
Date/Signature
29-06-2016
Industrial Inspection Services

J. Meijer

Agree authority (TUV SUD)

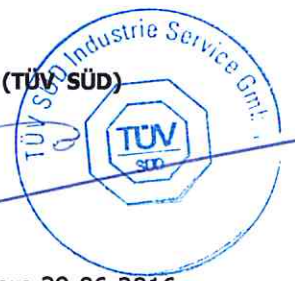

I van Remoortere 29-06-2016

2 pieces DIN-Flange ball valve full bore. Type AF90D/ AF94D

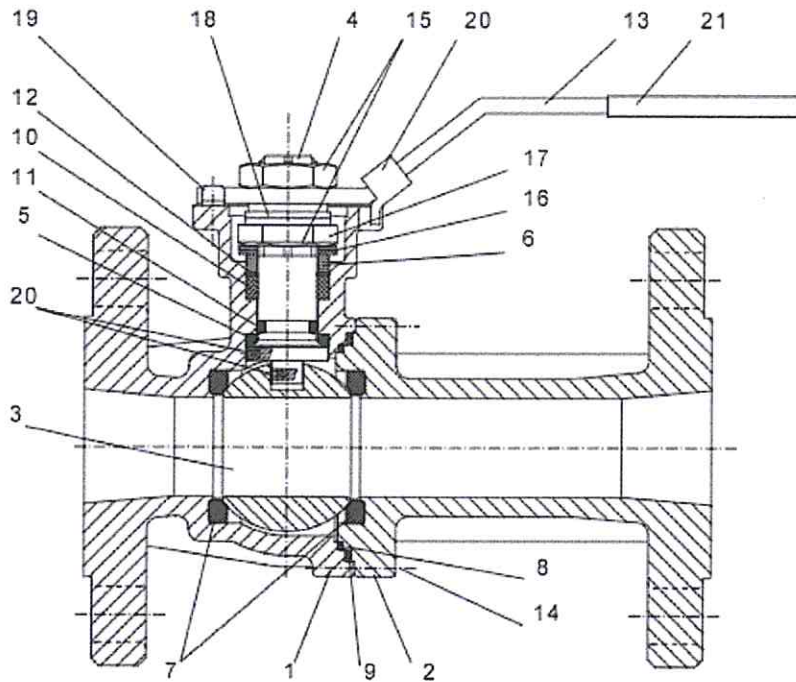

No.	Description	Material for stainless steel valve		Material for carbon steel valve	
1	Body	1.4408 / CF8M		1.0619 / A216 WCB	
2	Flange	1.4408 / CF8M		1.0619 / A216 WCB	
3	Ball	1.4401 / 316		1.4401 / 316	
4	Stem	1.4401 / 316		1.4401 / 316	
5	Stem washer	PTFE		PTFE	
6	Stem seal follower	1.4401 / 316		1.4401 / 316	
7	Seat Ring	RPTFE / PTFE / CPTFE		RPTFE / PTFE / CPTFE	
8	Body seal wetted	PTFE		PTFE	
9	Body seal outside	Graphite		Graphite	
10	Stem packing	Graphite		Graphite	
11	O-Ring (optional)	NBR / FEP		NBR / FEP	
12	Stem Shim	PTFE		PTFE	
13	Handle	1.4301 / 304		1.4301 / 304	
14	Hex screw	A2-70		A2-70	
15	Stem Nut	1.4301 / 304		1.4301 / 304	
16	Belleville washer	1.4310 / 301		1.4310 / 301	
17	Safety cap	1.4301 / 304		1.4301 / 304	
18	Distancer ring	1.4301 / 304		1.4301 / 304	
19	Stop device	1.4301 / 304		1.4301 / 304	
20	Locking device	1.4301 / 304		1.4301 / 304	
21	Sleeve	PVC		PVC	
	Type of valve	AF90D	AF94D	AF90D	AF94D
	Face to Face acc. DIN EN 558	Series 1	Series 27	Series 1	Series 27
	Weight	10.7 kg	9.7 kg	10.4 kg	9.4 kg

 Technology for Professionals	Drawn	R. Zingg	01.02.16
	Checked	RIZ	01.02.16
	Item fig	AF90D/ AF94D PN16/40	DN 50
	Drawing no.	1602231.03	



ITIS B.V.
 Daniëlsweg 6
 NL-4451 HP Heinkenszand
 T + 31 113 568515
 info@itis-nl.com
 www.itis-nl.com

ITIS Certificate
 201500169-C007 rev2



Industrie Service

API607 AND ISO 10497 FIRE TEST QUALIFICATION CERTIFICATE

This certificate is to certify that the valve below has been tested in accordance with, and meets all requirements stated in API Standard 607, sixth edition September 2010; Fire test for quarter turn valves and valves with non metallic seats, and ISO 10497 third edition 2010-02-15 Testing of valves - Fire- type testing requirements

Test valve details

Manufacturer : Zuercher Technik AG
 Address : Neumattstrasse 6, ch – 4450, Sissach, Switzerland
 Nominal size : DN65 – 2 ½”
 Pressure rating : PN16
 Flow direction : Bi- directional
 Type : Floating Ball valve – Series AF90D
 Weight : 15.1kg
 Drawing number : 1602232.02 date: 01-02-2016
 Body material : 1.0619/ A216 WCB
 Body gasket : Graphite
 Stud bolt/Nut material : A2-70 / A2-70
 Ball material : 1.4401/316
 Seat material : RPTFE
 Stem material : 1.4401/316
 Stem seal material : Graphite
 Identification No. : 00169007
 Markings on valve : Body material, heat no. and Serial number on valve body
 Gearbox : n.a.

Scope of other sizes, weight, pressures and materials qualified by this test.

Tested valve	7.3 Nominal Size	7.4 Pressure rating	7.1 d (e) Weight
NPS2 ½ class PN16 DN65	NPS2½; 3; 4 and 5 DN65; 80; 100 and 125	Class 150 PN16 and PN25	AF90D and valves with a mass >75%

For material qualification see paragraph 7.2 in report mentioned below.

This certificate is only valid in conjunction with the full ITIS BV test report number 201500169-R007 rev2

Name operator (ITIS)

TESTED
 REVIEW
 WITNESSED
 Date/Signature
 29-06-2016
 Industrie Service & Inspection Services

J. Meijer

Agree authority (TUV SUD)

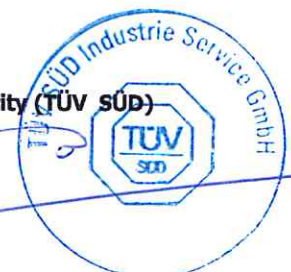

I van Remoortere 29-06-2016

2 pieces DIN-Flange ball valve full bore. Type AF90D / AF94D

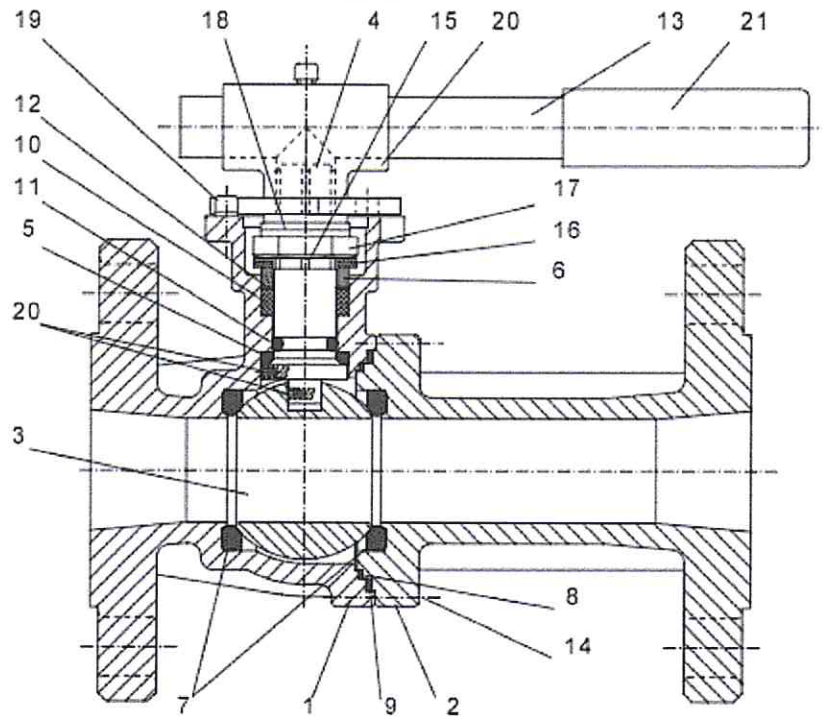

No.	Description	Material for stainless steel valve	Material for carbon steel valve
1	Body	1.4408 / CF8M	1.0619 / A216 WCB
2	Flange	1.4408 / CF8M	1.0619 / A216 WCB
3	Ball	1.4401 / 316	1.4401 / 316
4	Stem	1.4401 / 316	1.4401 / 316
5	Stem washer	PTFE	PTFE
6	Stem seal follower	1.4401 / 316	1.4401 / 316
7	Seat Ring	RPTFE / PTFE / CPTFE	RPTFE / PTFE / CPTFE
8	Body seal wetted	PTFE	PTFE
9	Body seal outside	Graphite	Graphite
10	Stem packing	Graphite	Graphite
11	O-Ring (optional)	NBR / FEP	NBR / FEP
12	Stem Shim	PTFE	PTFE
13	Handle	1.4301 / 304	1.4301 / 304
14	Hex screw	A2-70	A2-70
15	Stem Nut	1.4301 / 304	1.4301 / 304
16	Belleville washer	1.4310 / 301	1.4310 / 301
17	Safety cap	1.4301 / 304	1.4301 / 304
18	Distancer ring	1.4301 / 304	1.4301 / 304
19	Stop device	1.4301 / 304	1.4301 / 304
20	Adapter	1.4301 / 304	1.4301 / 304
21	Sleeve	PVC	PVC
	Type of valve	AF90D	AF94D
	Face to Face acc. DIN EN 558	Series 1	Series 27
	Weight	15.6 kg	14.2 kg

	Drawn	R. Zingg	01.02.16
	Checked	RIZ	01.02.16
	Item fig	AF90D AF94D PN16	DN 65
	Drawing no.	1602232.02	

ITIS B.V.

Daniëlsweg 6
 NL-4451 HP Heinkenszand
 T + 31 113 568515
 info@itis-nl.com
 www.itis-nl.com

Report
 201500169-R005 rev2



Report: 201500169-R005			
Client: Zuercher Technik AG	Reference: Mr. R. Zingg	Purchase order No. : 62017519	Annex. : 1: Valve assembly drawing 2: Pressure test certificate
Operator: J. Meijer	Test date: 03-03-2016	Test: Fire test	Procedure: API standard 607 6 th edition, Sept.2010 ISO 10497 third edition 2010-02-15 Testing of valves - Fire- type testing requirements

Foreword

On 03-03-2016 at the ITIS valve test laboratory in Heinkenszand, the Netherlands, a Fire Test was conducted on behalf of Zuercher Technik AG. The Fire Test was performed in accordance to API Standard 607, sixth edition September 2010; Fire test for quarter turn valves and valves with non metallic seats, and ISO 10497 third edition 2010-02-15 Testing of valves - Fire- type testing requirements. The valve was selected and supplied by the manufacturer Zuercher Technik AG.

Test valve details

Manufacturer : Zuercher Technik AG
 Address : Neumattstrasse 6, ch – 4450, Sissach, Switzerland
 Nominal size : DN50 – 2”
 Pressure rating : PN40
 Flow direction : Bi- directional
 Type : Floating Ball valve, Series AF90D
 Weight : 10.4kg
 Drawing number : 1602231.03 date: 01-02-2016
 Body material : 1.0619/A216 WCB
 Body gasket : Graphite
 Stud bolt/Nut material : A2-70 / A2-70
 Ball material : 1.4401 / 316
 Seat material : RPTFE
 Stem material : 1.4401 / 316
 Stem seal material : Graphite
 Identification No. : 00169005 (by ITIS)
 Markings on valve : Body material, heat no. and Serial number on valve body
 Gearbox : n.a.

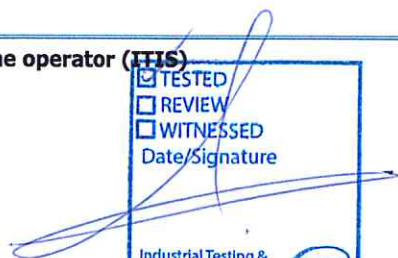
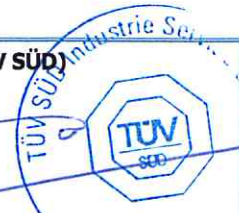
Name operator (ITIS) <input checked="" type="checkbox"/> TESTED <input type="checkbox"/> REVIEW <input type="checkbox"/> WITNESSED Date/Signature  J. Meijer Industrial Testing & Inspection Services 29-06-2016		Name Authority (TÜV SÜD)  I van Remoortere 29-06-2016
--	--	--

ITIS B.V.

Daniëlsweg 6
 NL-4451 HP Heinkenszand
 T + 31 113 568515
 info@itis-nl.com
 www.itis-nl.com

Report
 201500169-R005 rev2

**Requirements and limits****Test pressure**

High test pressure : 30barg, 75% of rated seat pressure at 20°C
 Low test pressure : 2barg

Through seat leakage

During burn : 200ml/min
 After cool-down : 80ml/min

External leakage

During burn and cool-down : 50ml/min
 After operational test : 50ml/min

Maximum cavity pressure

1.5 times rated pressure : 60barg

Test equipment

Pressure gauge : PG160-001, 0-160barg
 Digital pressure gauge : DPG600-1 and DPG600-2, 0-600barg
 Flow meter 007 : Aquadis, serial number 11LA102308
 Temperature recorder : Eurotherm Chessel 5180A; ITIS No.ITISREC004
 Thermocouples : Type K

Test preparation

Valve was supplied with blind end connections to which the DN25 test systems piping was welded on. This to make sure that no leakage of these parts could affect the actual test results. The valve was mounted into the test rig with calorimeter cubes and flame environment thermocouples in their appropriate locations as in Figure 3 & 4 of the standard, these in turn being connected with the ITIS log and registration software. With the valve in the partially open position the system was checked for leaks by pressurizing the system to 1.4 times the maximum permissible working pressure at 20°C. The system was pressurized to the appropriate test pressure as in paragraph 5.6.4. The water flow meter (4) was reset to zero, and seat leakage container (18) was emptied. If necessary the system, excluding the valve, shall be adjusted during the test period to maintain the temperatures and pressures required.

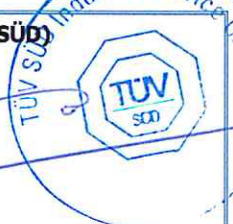
<p>Name operator (ITIS)</p> <p><input checked="" type="checkbox"/> TESTED <input type="checkbox"/> REVIEW <input type="checkbox"/> WITNESSED Date/Signature</p> <p>J. Meijer</p> <p>Industrial Testing & Inspection Services  29-06-2016</p>		<p>Name Authority (TUV SÜD)</p> <p>I van Remoortere</p> <p> 29-06-2016</p>
--	--	---



Test performance

Time	Test description (Par.)	Required value	Measured value	Acceptable
Start-end	All values were recorded continuously during the complete test period. (5.6.9)			
11:27 – 11:29	Burn period needed to reach all required flame temperatures. (5.6.7)	≤2min.	2min.	Yes
11:27 – 11:42	Burn period needed to reach all required calorimeter cubes temperatures (5.6.8)	≤15min.	15min.	Yes
11:37 11:42	Total burn period that the body and bonnet where the required temperatures: (5.6.8)	Bonnet: ≥15min. Body: ≥25min.	10min. 15min.	Yes Yes
11:57	Total through seat leakage during burn period at 30barg (5.6.11) (maximum leakage: 200ml/min. x 30min.)	≤6000ml	0ml	Yes
12:02 – 12:07	Total period the valve was force-cooled with water to make sure that external surface temperature will remain below 100°C. (5.6.12) Total cool down period:	≤10min. ≤15min.	5min. 10min.	Yes
12:07	Total external leakage during burn and cool down period at 30barg (5.6.13) (maximum leakage: 50ml/min. x 40min.)	≤2000ml	0ml	Yes
12:08 – 12:13	Low pressure through seat leakage test at 2barg, for valves classes ≤ 600 or PN100. (5.6.14) (max. 80ml/min. x 5min.)	≤400ml	20ml	Yes
12:16	High pressure operational test, valve has to be fully opened against the high test pressure of 30barg. (5.6.15)	Smooth operation	Smooth operation	Yes
12:17 – 12:22	Total external leakage during a 5 minute period At the high test pressure of 30barg (5.6.16) (maximum leakage: 50ml/min. x 5min.)	≤250ml	0ml	Yes

Name operator (ITIS)

TESTED
 REVIEW
 WITNESSED
 Date/Signature

J. Meijer

Industrial Testing & Inspection Service
 29-06-2016

Name Authority (TÜV SÜD)

I van Remoortere

29-06-2016

ITIS B.V.

Daniëlsweg 6
 NL-4451 HP Heinkenszand
 T + 31 113 568515
 info@itis-nl.com
 www.itis-nl.com

Report
 201500169-R005 rev2

**Remarks**

All required temperatures were reached within the specified time limits.

Conclusion

The valve meets all requirements stated in API Standard 607, sixth edition September 2010; Fire test for quarter turn valves and valves with non metallic seats, ISO 10497 third edition 2010-02-15 Testing of valves - Fire- type testing requirements. The test was witnessed by Mr. I. van Remoortere representing TÜV SÜD Industrie Service GmbH.

Scope of other sizes, pressures and materials qualified by this test.

7.1 d A reduced bore (or Venturi pattern test valve may be used to qualify a smaller nominal size full bore (or regular pattern) valve when the components associated with the obturator, seat seals and stem are identical in design and size. In such a case, the permissible average leakage rate are those applicable to the full bore (or regular pattern) valve.

7.1 e The type of valve body ends are not considered by this International Standard. However, the mass of the valve is determined in part by body end type. For qualification to the present International Standard, and providing that all other qualification criteria have been met, valves with ends different to those of the test valve may also qualify provided that their mass is greater than that of the test valve, or their mass is not less than 75% of that of the test valve.

7.2.1 For the purposes of product compliance certification or type testing systems, the materials of construction of the pressure retaining envelope of the valve shall be deemed to qualify other materials of construction within the generic classifications below:
 -Ferritic,
 -Austenitic,
 -Duplex.

7.2.2 If a range of valves is covered by testing of ferritic test valves then the type-testing coverage may be extended to cover austenitic or duplex materials by carrying out a further test on a mid-range size of valve of the same design in that material.

7.2.3 Other materials of construction of the pressure-retaining envelope of the valve require full testing of representative size and pressure ratings as specified in 7.3 and 7.4.

7.2.4 Alloy steel bolting (e.g. B7, L7) used as part of the pressure-retaining envelope may be used to qualify austenitic steel bolting, but not vice-versa.

7.2.5 Any change in non-metallic materials with respect to the seat-to-closure member seal, seat-to-body seal, stem seal and body joint and seal require a re-qualification. Filled PTFE, however, may qualify non-filled PTFE and vice-versa.

Tested valve	7.3 Nominal Size	7.4 Pressure rating	7.1 d (e) Weight
NPS2 class 300 DN50	NPS2 and below, 2½, 3 and 4 DN50 and below, 65, 80 and 100	Class 300; 400 and 600 PN40, PN63, and PN100	AF90D and valves with a mass >75%

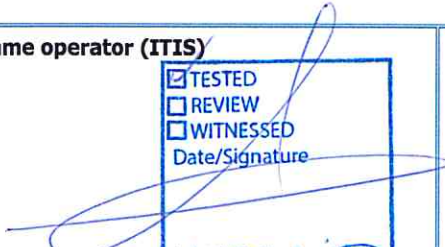
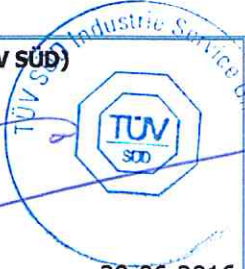
Name operator (ITIS) <input checked="" type="checkbox"/> TESTED <input type="checkbox"/> REVIEW <input type="checkbox"/> WITNESSED Date/Signature  J. Meijer Industrial Testing & Inspection Services 29-06-2016	Name Authority (TÜV SÜD)  I van Remoortere 29-06-2016
--	--



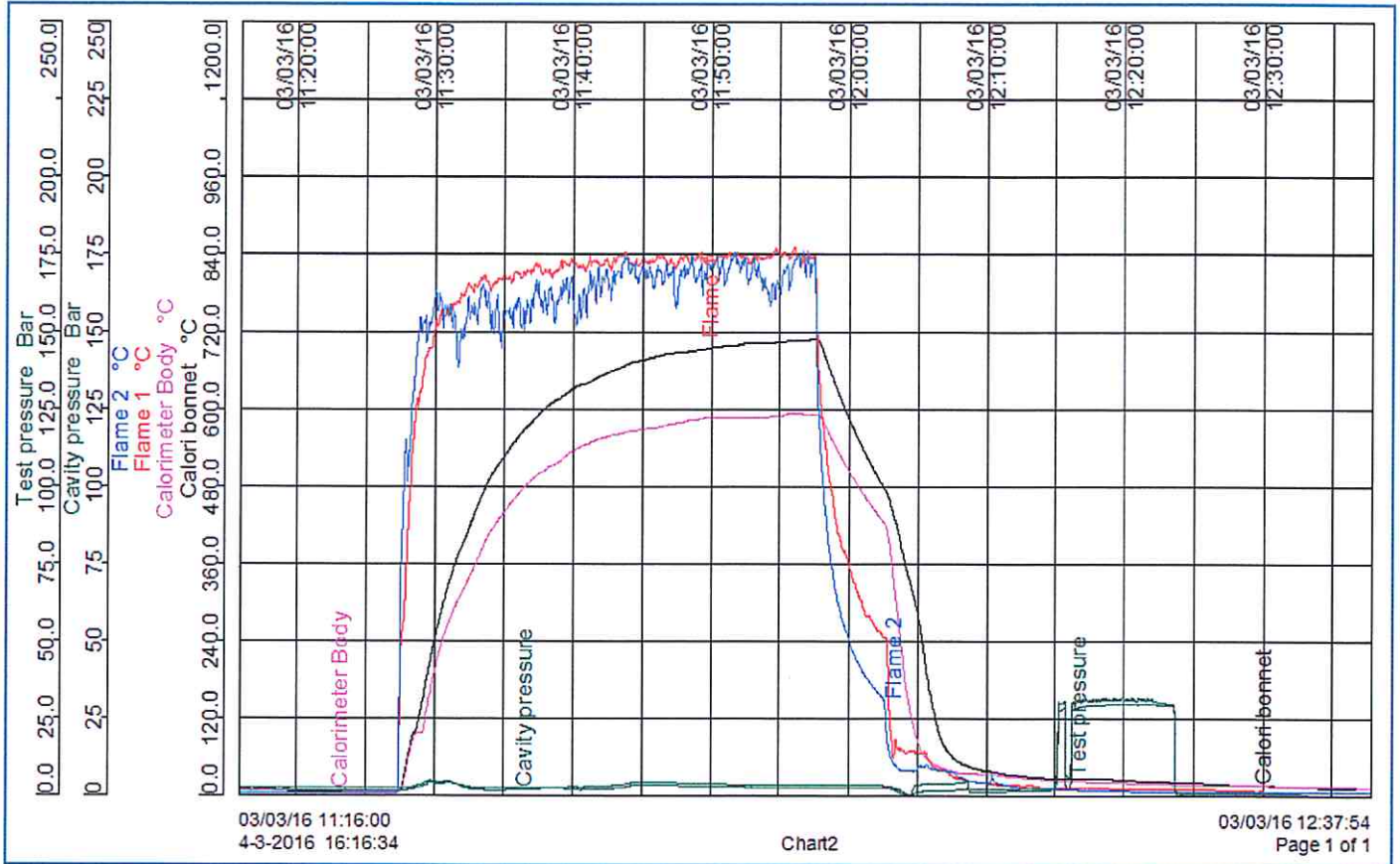

Temperature chart

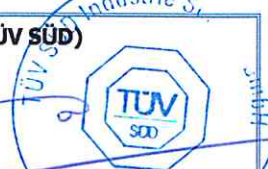

<p>Name operator (ITIS)</p> <p><input checked="" type="checkbox"/> TESTED <input type="checkbox"/> REVIEW <input type="checkbox"/> WITNESSED Date/Signature</p> <p>J. Meijer</p> <p>Industrial Testing & Inspection Services 29-06-2016</p>		<p>Name Authority (TÜV SÜD)</p> <p>I van Remoortere</p> <p>29-06-2016</p> 
---	--	---

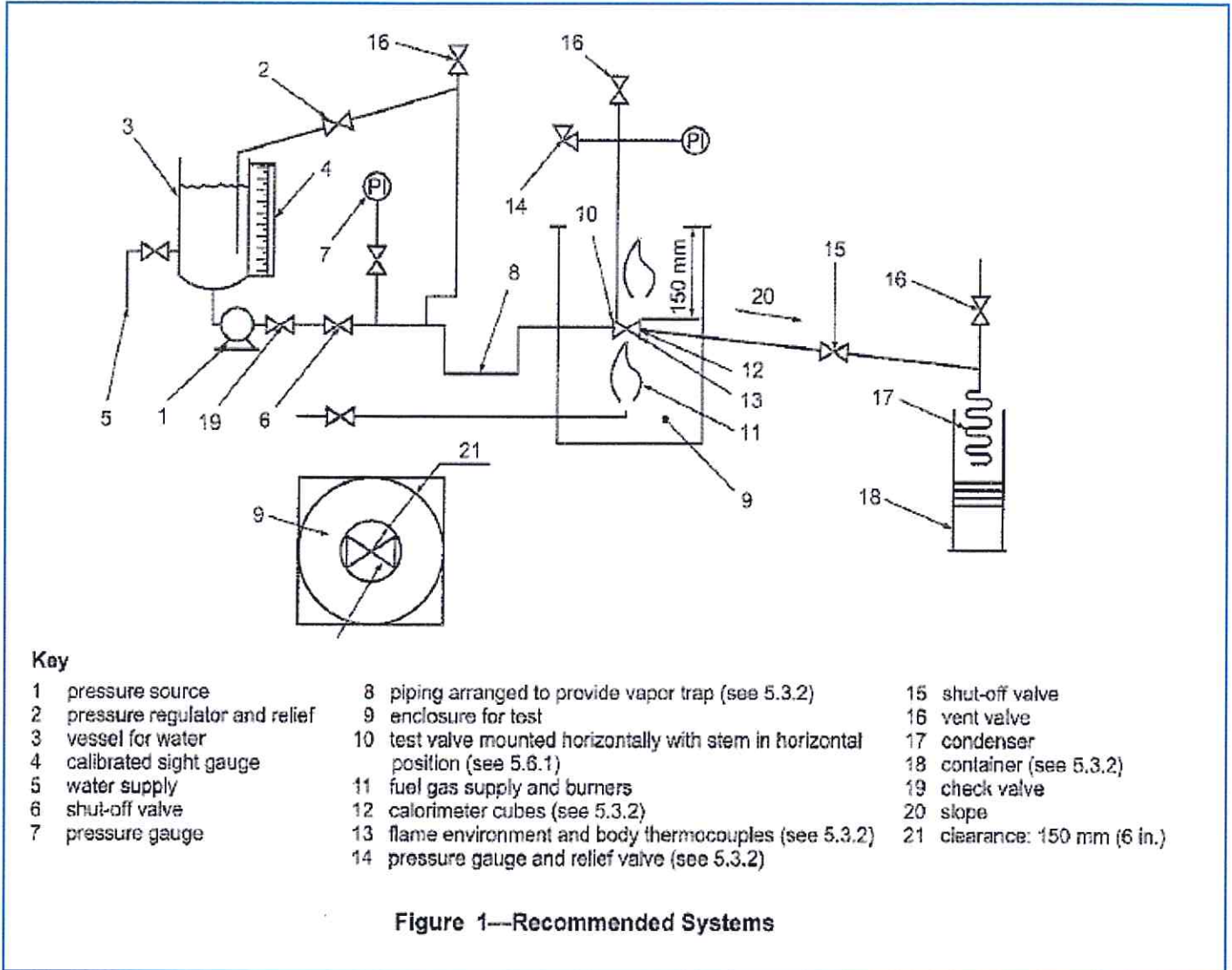
Test setup



<p>Name operator (ITIS)</p> <p><input checked="" type="checkbox"/> TESTED <input type="checkbox"/> REVIEW <input type="checkbox"/> WITNESSED Date/Signature</p> <p>J. Meijer</p> <p>Industrial Testing & Inspection Services  29-06-2016</p>		<p>Name Authority (TÜV SÜD)</p> <p></p> <p>I van Remoortere</p> <p>29-06-2016</p>
--	--	--

ITIS B.V.

Daniëlsweg 6
NL-4451 HP Heinkenszand
T + 31 113 568515
info@itis-nl.com
www.itis-nl.com

Report
201500169-R005 rev2



Actual fire

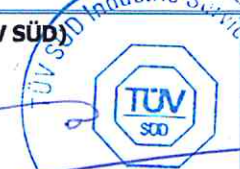

<p>Name operator (ITIS)</p> <p><input checked="" type="checkbox"/> TESTED <input type="checkbox"/> REVIEW <input type="checkbox"/> WITNESSED Date/Signature</p> <p>J. Meijer</p> <p>Industrial Testing & Inspection Service</p> <p>29-06-2016</p>		<p>Name Authority (TÜV SÜD)</p> <p>I van Remoortere</p> <p>29-06-2016</p> 
--	--	--



Valve identification

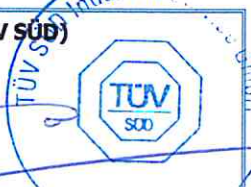

<p>Name operator (ITIS)</p> <p><input checked="" type="checkbox"/> TESTED <input type="checkbox"/> REVIEW <input type="checkbox"/> WITNESSED Date/Signature</p> <p>J. Meijer</p> <p>Industrial Testing & Inspection Services</p> <p>29-06-2016</p>		<p>Name Authority (TÜV SÜD)</p> <p>I van Remoortere</p> <p>29-06-2016</p> 
--	--	---

2 pieces DIN-Flange ball valve full bore. Type AF90D/ AF94D

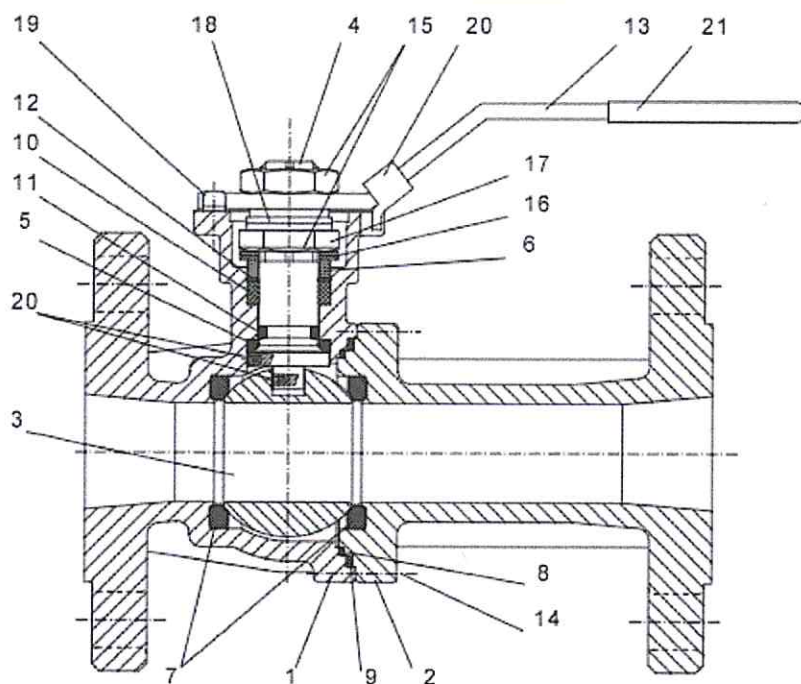

No.	Description	Material for stainless steel valve	Material for carbon steel valve
1	Body	1.4408 / CF8M	1.0619 / A216 WCB
2	Flange	1.4408 / CF8M	1.0619 / A216 WCB
3	Ball	1.4401 / 316	1.4401 / 316
4	Stem	1.4401 / 316	1.4401 / 316
5	Stem washer	PTFE	PTFE
6	Stem seal follower	1.4401 / 316	1.4401 / 316
7	Seat Ring	RPTFE / PTFE / CPTFE	RPTFE / PTFE / CPTFE
8	Body seal wetted	PTFE	PTFE
9	Body seal outside	Graphite	Graphite
10	Stem packing	Graphite	Graphite
11	O-Ring (optional)	NBR / FEP	NBR / FEP
12	Stem Shim	PTFE	PTFE
13	Handle	1.4301 / 304	1.4301 / 304
14	Hex screw	A2-70	A2-70
15	Stem Nut	1.4301 / 304	1.4301 / 304
16	Belleville washer	1.4310 / 301	1.4310 / 301
17	Safety cap	1.4301 / 304	1.4301 / 304
18	Distancer ring	1.4301 / 304	1.4301 / 304
19	Stop device	1.4301 / 304	1.4301 / 304
20	Locking device	1.4301 / 304	1.4301 / 304
21	Sleeve	PVC	PVC
	Type of valve	AF90D	AF94D
	Face to Face acc. DIN EN 558	Series 1	Series 27
	Weight	10.7 kg	9.7 kg

	Drawn	R. Zingg	01.02.16
	Checked	RIZ	01.02.16
	Item fig	AF90D/ AF94D PN16/40	DN 50
	Drawing no.	1602231.03	

	Druckprüfprotokoll 90D/94D Pressure test report 90D/94D	90D/94D
		FO_011.00 Seite: 1 von 1

Druckprüfprotokoll nach DIN EN 2266-1

Pressure test report acc. to DIN EN 12266-1

Unsere Auftrags-Nummer (our order number): 62017519 Position (item): 4

Artikel-Nummer (article number): 09050D.000T1

Nenngrösse (DN) (nominal size) / Nenndruck (PN) (nominal pressure): DN 50 PN 40

Losgrösse (batch) Stk. (pcs): 1 pc

Charge Nr. der geprüften Kugelhähne
Melting-No. of tested Ball Valves

Nr./ no.	1	2
GT/ body	C2F10	
FT/ flange	C2F12	
	WCB	

Drehmoment an der Spindel (stem torque):
 Manuell, --- Nm
 manually --- Nm

P10 / P11 (BA)

Prüfdruck (testing pressure): 60 bar (PN x 1.5)

Prüfzeit (testing time): 2 Min. (minutes)

P12 (BO)

Prüfdruck (testing pressure): 6 bar

Prüfzeit (testing time): 20 sec

	Ja / (yes)	Nein / (no)	Fehlermeldung (report of fault)
P10 / P11 (BA) Test bestanden (test fulfilled): Leckrate A	X		
P12 (BO) Test bestanden (test fulfilled): Leckrate A	X		

CE - Kennzeichnung (CE marking) DN32 - DN100

Los-Nr (batch number): Quartal (quarter) ----- Jahr (year) ----- Beispiel: 1 / 10
 Sample: 1 / 10

Die obengenannte(n) Armatur(n) wurde(n) in unserem Werk nach SN EN 12266- 1 mit dem aufgeführten Prüfdruck einer Druckprüfung unterzogen.

(Above mentioned ball valves have been tested in our factory acc. to SN EN 12266-1 to above listed pressure.)

Bemerkungen (Remarks):

Tested without NPT 1/ 4"

Datum und Visum des Prüfers (Date and signature of tester):

10.02.2016 Richard Zingg

Erstellt: 13.09.2013 ROG	Freigabe: 25.09.2013 ROG	
Geändert:		

ITIS B.V.

Daniëlsweg 6
 NL-4451 HP Heinkenszand
 T + 31 113 568515
 info@itis-nl.com
 www.itis-nl.com

Report
 201500169-R007 rev2



Report: 201500169-R007			
Client: Zuercher Technik AG	Reference: Mr. R. Zingg	Purchase order No. : 62017519	Annex. : 1: Valve assembly drawing 2: Pressure test certificate
Operator: J. Meijer	Test date: 04-03-2016	Test: Fire test	Procedure: API standard 607 6 th edition, Sept.2010 ISO 10497 third edition 2010-02-15 Testing of valves - Fire- type testing requirements

Foreword

On 04-03-2016 at the ITIS valve test laboratory in Heinkenszand, the Netherlands, a Fire Test was conducted on behalf of Zuercher Technik AG. The Fire Test was performed in accordance to API Standard 607, sixth edition September 2010; Fire test for quarter turn valves and valves with non metallic seats, and ISO 10497 third edition 2010-02-15 Testing of valves - Fire- type testing requirements. The valve was selected and supplied by the manufacturer Zuercher Technik AG.

Test valve details

Manufacturer : Zuercher Technik AG
 Address : Neumattstrasse 6, ch – 4450, Sissach, Switzerland
 Nominal size : DN65 - 2 ½"
 Pressure rating : PN16
 Flow direction : Bi- directional
 Type : Floating Ball valve – Series AF90D
 Weight : 15.1kg
 Drawing number : 1602232.02 date: 01-02-2016
 Body material : 1.0619/ A216 WCB
 Body gasket : Graphite
 Stud bolt/Nut material : A2-70 / A2-70
 Ball material : 1.4401 / 316
 Seat material : RPTFE
 Stem material : 1.4401 / 316
 Stem seal material : Graphite
 Identification No. : 00169007
 Markings on valve : Body material, heat no. and Serial number on valve body
 Gearbox : n.a.

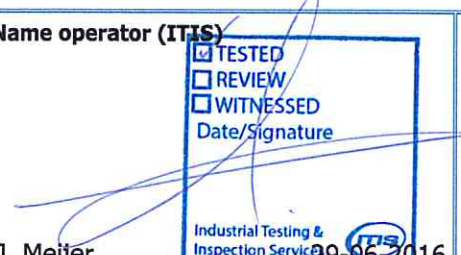
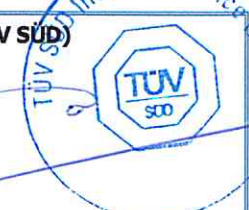
Name operator (ITIS) <input checked="" type="checkbox"/> TESTED <input type="checkbox"/> REVIEW <input type="checkbox"/> WITNESSED Date/Signature  J. Meijer Industrial Testing & Inspection Service 29-06-2016		Name Authority (TÜV SÜD)  I van Remoortere 29-06-2016
--	--	--

ITIS B.V.

Daniëlsweg 6
 NL-4451 HP Heinkenszand
 T + 31 113 568515
 info@itis-nl.com
 www.itis-nl.com

Report
 201500169-R007 rev2

**Requirements and limits****Test pressure**

High test pressure : 12barg, 75% of rated seat pressure at 20°C
 Low test pressure : 2barg

Through seat leakage

During burn : 260ml/min
 After cool-down : 104ml/min

External leakage

During burn and cool-down : 65ml/min
 After operational test : 65ml/min

Maximum cavity pressure

1.5 times rated pressure : 24barg

Test equipment

Pressure gauge : PG060-001, 0-60barg
 Digital pressure gauge : DPG600-1 and DPG600-2, 0-600barg
 Flow meter 007 : Aquadis, serial number 11LA102308
 Temperature recorder : Eurotherm Chessel 5180A; ITIS No.ITISREC004
 Thermocouples : Type K

Test preparation

Valve was supplied with blind end connections to which the DN25 test systems piping was welded on. This to make sure that no leakage of these parts could affect the actual test results. The valve was mounted into the test rig with calorimeter cubes and flame environment thermocouples in their appropriate locations as in Figure 3 & 4 of the standard, these in turn being connected with the ITIS log and registration software. With the valve in the partially open position the system was checked for leaks by pressurizing the system to 1.4 times the maximum permissible working pressure at 20°C. The system was pressurized to the appropriate test pressure as in paragraph 5.6.4. The water flow meter (4) was reset to zero, and seat leakage container (18) was emptied. If necessary the system, excluding the valve, shall be adjusted during the test period to maintain the temperatures and pressures required.

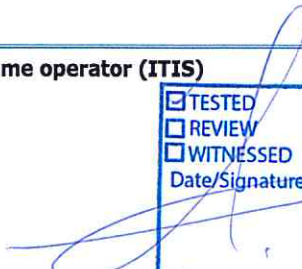
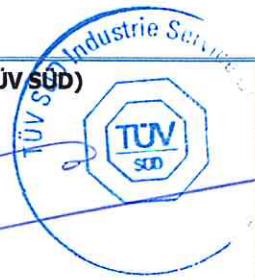
Name operator (ITIS) <input checked="" type="checkbox"/> TESTED <input checked="" type="checkbox"/> REVIEW <input checked="" type="checkbox"/> WITNESSED Date/Signature  J. Meijer Industrial Testing & Inspection Services 29-06-2016		Name Authority (TÜV SÜD)  I van Remoortere 29-06-2016
--	--	--



Test performance

Time	Test description (Par.)	Required value	Measured value	Acceptable
Start-end	All values were recorded continuously during the complete test period. (5.6.9)			
9:20 – 9:22	Burn period needed to reach all required flame temperatures. (5.6.7)	≤2min.	2min.	Yes
9:33	Burn period needed to reach all required calorimeter cubes temperatures (5.6.8)	≤15min.	13min.	Yes
9:26 9:44	Total burn period that the body and bonnet where the required temperatures: (5.6.8)	Bonnet: ≥15min. Body: ≥25min.	6min. 24min.	Yes Yes
9:50	Total through seat leakage during burn period at 2barg (5.6.11) (maximum leakage: 260ml/min. x 30min.)	≤7800ml	100ml	Yes
9:55 – 10:00	Total period the valve was force-cooled with water to make sure that external surface temperature will remain below 100°C. (5.6.12) Total cool down period:	≤10min. ≤15min.	5min. 10min.	Yes
10:00	Total external leakage during burn and cool down period at 2barg (5.6.13) (maximum leakage: 65ml/min. x 40min.)	≤2600ml	0ml	Yes
10:05 – 10:10	Low pressure through seat leakage test at 2barg, for valves classes ≤ 600 or PN100. (5.6.14) (max. 104ml/min. x 5min.)	≤520ml	50ml	Yes
10:15	High pressure operational test, valve has to be fully opened against the high test pressure of 12barg. (5.6.15)	Smooth operation	Yes	Yes
10:15 – 10:20	Total external leakage during a 5 minute period At the high test pressure of 12barg (5.6.16) (maximum leakage: 65ml/min. x 5min.)	≤325ml	235ml	Yes

<p>Name operator (ITIS)</p> <p><input checked="" type="checkbox"/> TESTED <input type="checkbox"/> REVIEW <input type="checkbox"/> WITNESSED Date/Signature</p> <p>J. Meijer Industrial Testing & Inspection Services 29-06-2016</p>		<p>Name Authority (TÜV SÜD)</p> <p>TÜV SÜD Industrie Service GmbH I van Remoortere 29-06-2016</p>
--	--	--

ITIS B.V.

Daniëlsweg 6
 NL-4451 HP Heinkenszand
 T + 31 113 568515
 info@itis-nl.com
 www.itis-nl.com

Report
 201500169-R007 rev2

**Remarks**

All required temperatures were reached within the specified time limits.

Conclusion

The valve meets all requirements stated in API Standard 607, sixth edition September 2010; Fire test for quarter turn valves and valves with non metallic seats, ISO 10497 third edition 2010-02-15 Testing of valves - Fire- type testing requirements. The test was witnessed by Mr. I. van Remoortere representing TÜV SÜD Industrie Service GmbH.

Scope of other sizes, pressures and materials qualified by this test.

7.1 d A reduced bore (or Venturi pattern test valve may be used to qualify a smaller nominal size full bore (or regular pattern) valve when the components associated with the obturator, seat seals and stem are identical in design and size. In such a case, the permissible average leakage rate are those applicable to the full bore (or regular pattern) valve.

7.1 e The type of valve body ends are not considered by this International Standard. However, the mass of the valve is determined in part by body end type. For qualification to the present International Standard, and providing that all other qualification criteria have been met, valves with ends different to those of the test valve may also qualify provided that their mass is greater than that of the test valve, or their mass is not less than 75% of that of the test valve.

7.2.1 For the purposes of product compliance certification or type testing systems, the materials of construction of the pressure retaining envelope of the valve shall be deemed to qualify other materials of construction within the generic classifications below:
 -Ferritic,
 -Austenitic,
 -Duplex.

7.2.2 If a range of valves is covered by testing of ferritic test valves then the type-testing coverage may be extended to cover austenitic or duplex materials by carrying out a further test on a mid-range size of valve of the same design in that material.

7.2.3 Other materials of construction of the pressure-retaining envelope of the valve require full testing of representative size and pressure ratings as specified in 7.3 and 7.4.

7.2.4 Alloy steel bolting (e.g. B7, L7) used as part of the pressure-retaining envelope may be used to qualify austenitic steel bolting, but not vice-versa.

7.2.5 Any change in non-metallic materials with respect to the seat-to-closure member seal, seat-to-body seal, stem seal and body joint and seal require a re-qualification. Filled PTFE, however, may qualify non-filled PTFE and vice-versa.

Tested valve	7.3 Nominal Size	7.4 Pressure rating	7.1 d (e) Weight
NPS2 ½ class PN16 DN65	NPS2½; 3; 4 and 5 DN65; 80; 100 and 125	Class 150 PN16 and PN25	AF90D and valves with a mass >75%

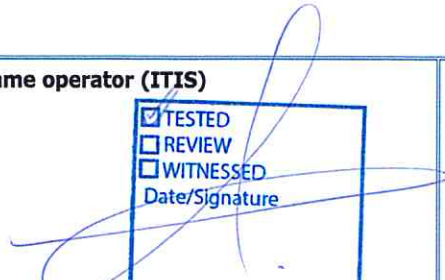
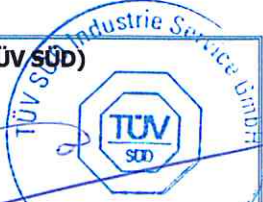
Name operator (ITIS) <input checked="" type="checkbox"/> TESTED <input type="checkbox"/> REVIEW <input type="checkbox"/> WITNESSED Date/Signature  J. Meijer Industrial Testing & Inspection Services 29-06-2016		Name Authority (TÜV SÜD)  I van Remoortere 29-06-2016
--	--	--



Temperature chart

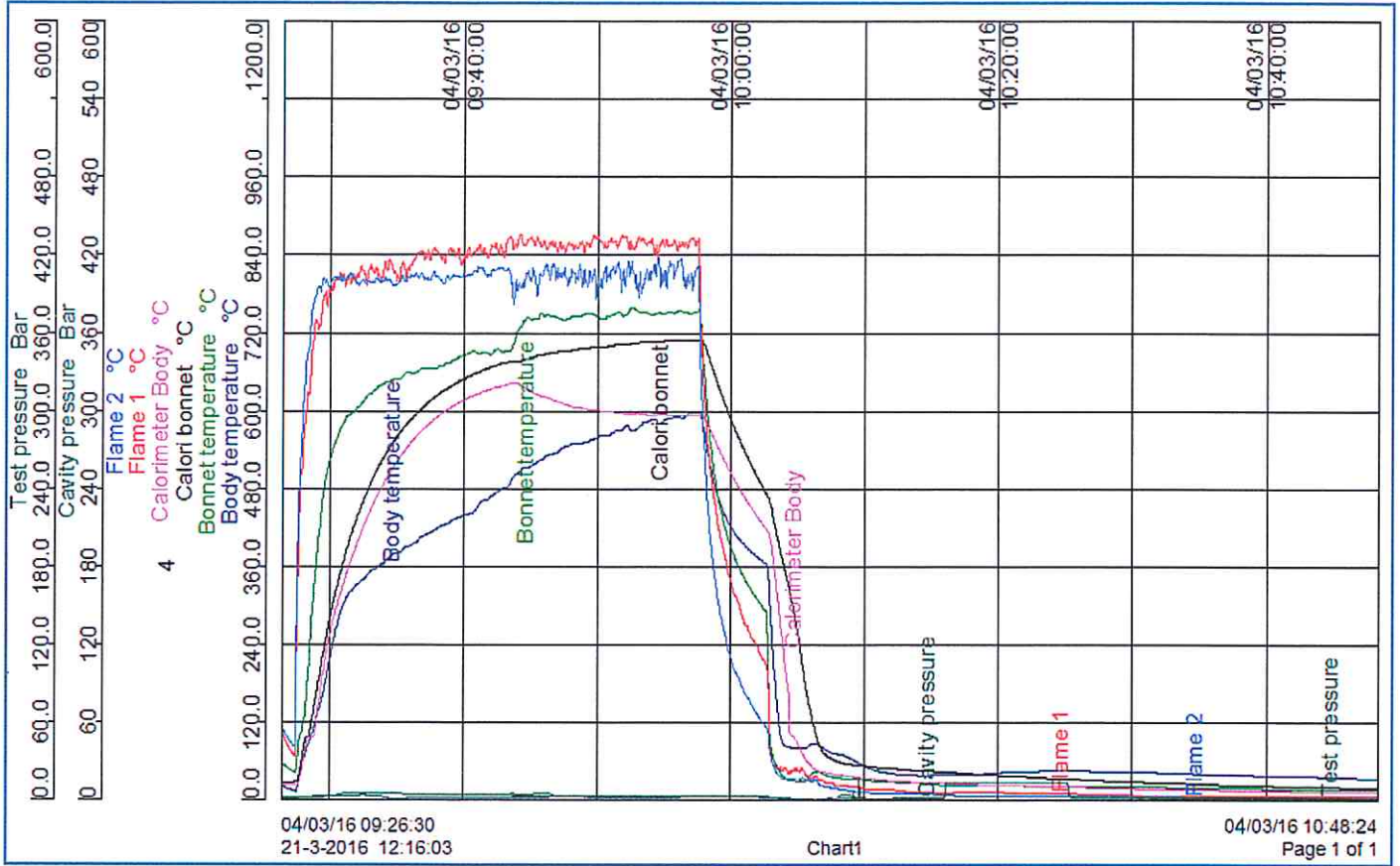

Name operator (ITIS)

TESTED
 REVIEW
 WITNESSED
 Date/Signature

J. Meijer

Industrial Testing & Inspection Services
 29-06-2016

Name Authority (TUV SUD)

I van Remoortere

29-06-2016



Test setup

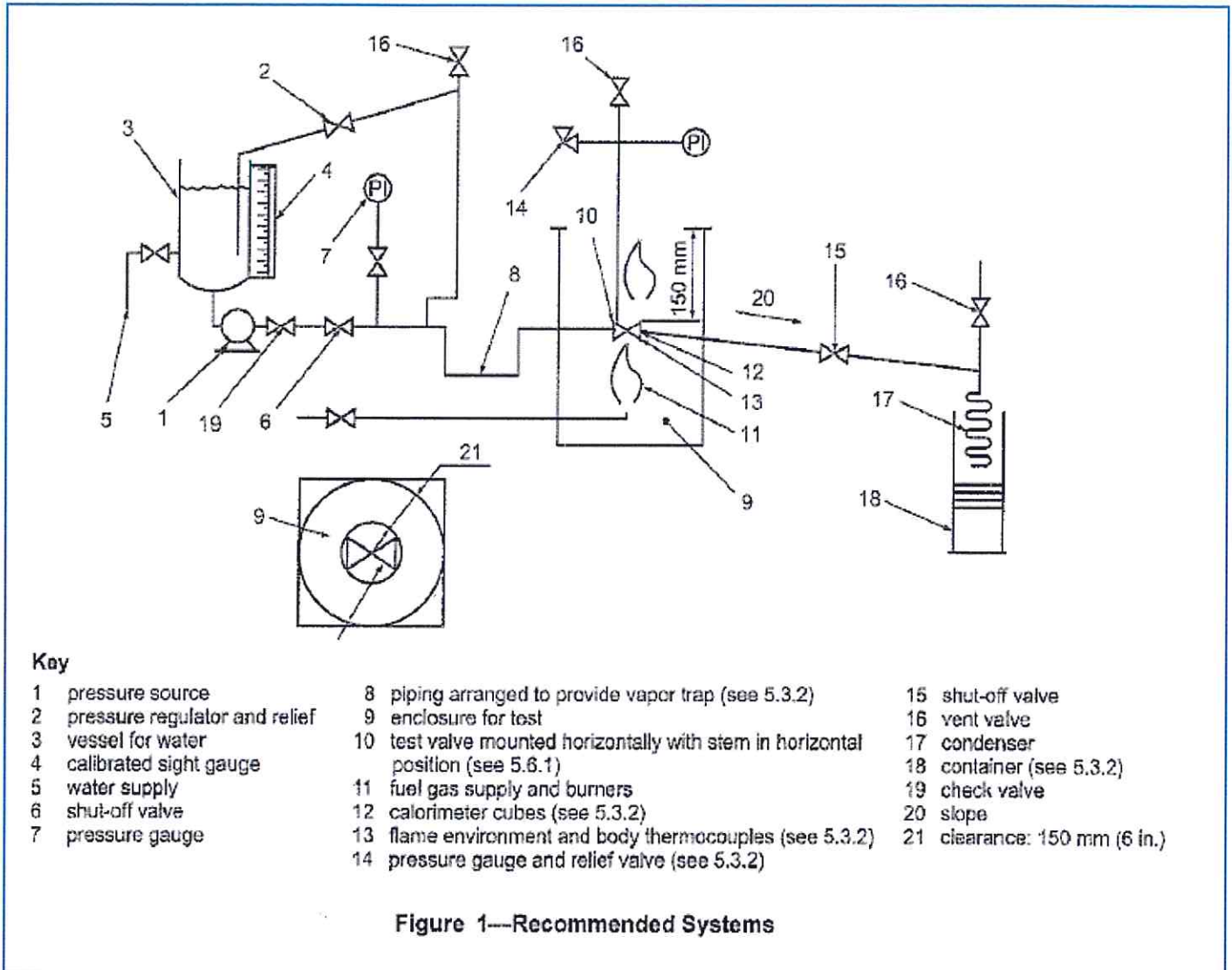

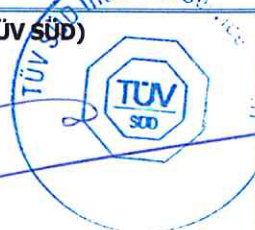

<p>Name operator (ITIS)</p> <p><input checked="" type="checkbox"/> TESTED <input type="checkbox"/> REVIEW <input type="checkbox"/> WITNESSED Date/Signature</p> <p>J. Meijer Industrial Testing & Inspection Service 29-06-2016</p>		<p>Name Authority (TUV SÜD)</p> <p>I van Remoortere 29-06-2016</p> 
---	--	--



Actual fire



<p>Name operator (ITIS)</p> <p><input checked="" type="checkbox"/> TESTED <input type="checkbox"/> REVIEW <input type="checkbox"/> WITNESSED Date/Signature</p> <p>J. Meijer</p> <p>Industrial Testing & Inspection Services  29-06-2016</p>		<p>Name Authority (TÜV SÜD)</p> <p>I van Remoortere</p> <p> 29-06-2016</p>
---	--	---



Valve identification

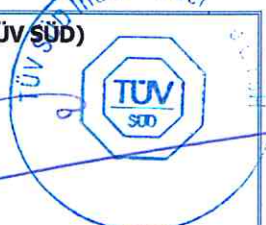

<p>Name operator (ITIS)</p> <p><input checked="" type="checkbox"/> TESTED <input type="checkbox"/> REVIEW <input type="checkbox"/> WITNESSED Date/Signature</p> <p>J. Meijer</p> <p>Industrial Testing Inspection Services</p> <p>29-06-2016</p>		<p>Name Authority (TÜV SÜD)</p> <p>I van Remoortere</p> <p>29-06-2016</p> 
--	--	---

2 pieces DIN-Flange ball valve full bore. Type AF90D / AF94D

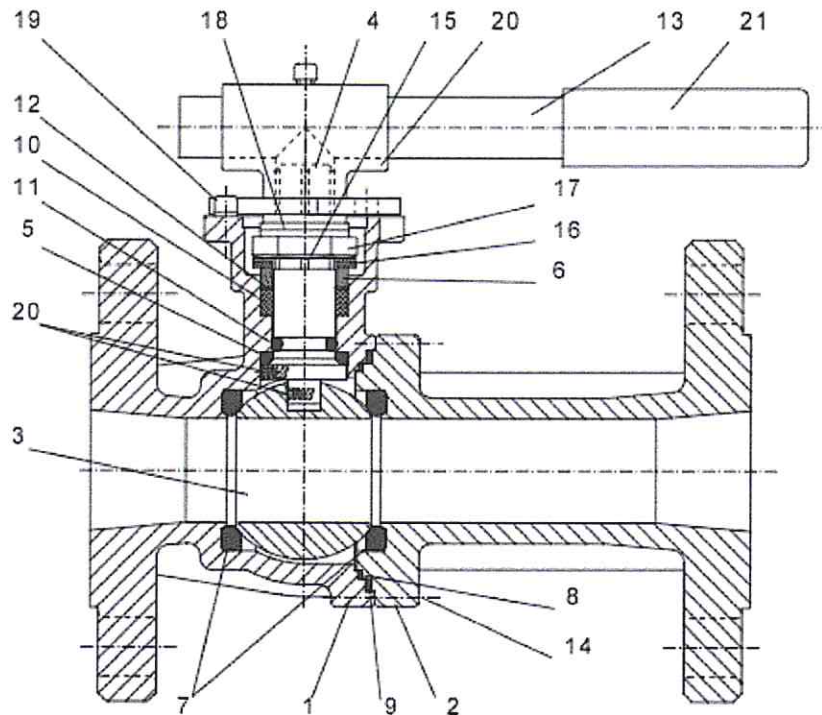

No.	Description	Material for stainless steel valve	Material for carbon steel valve		
1	Body	1.4408 / CF8M	1.0619 / A216 WCB		
2	Flange	1.4408 / CF8M	1.0619 / A216 WCB		
3	Ball	1.4401 / 316	1.4401 / 316		
4	Stem	1.4401 / 316	1.4401 / 316		
5	Stem washer	PTFE	PTFE		
6	Stem seal follower	1.4401 / 316	1.4401 / 316		
7	Seat Ring	RPTFE / PTFE / CPTFE	RPTFE / PTFE / CPTFE		
8	Body seal wetted	PTFE	PTFE		
9	Body seal outside	Graphite	Graphite		
10	Stem packing	Graphite	Graphite		
11	O-Ring (optional)	NBR / FEP	NBR / FEP		
12	Stem Shim	PTFE	PTFE		
13	Handle	1.4301 / 304	1.4301 / 304		
14	Hex screw	A2-70	A2-70		
15	Stem Nut	1.4301 / 304	1.4301 / 304		
16	Belleville washer	1.4310 / 301	1.4310 / 301		
17	Safety cap	1.4301 / 304	1.4301 / 304		
18	Distancer ring	1.4301 / 304	1.4301 / 304		
19	Stop device	1.4301 / 304	1.4301 / 304		
20	Adapter	1.4301 / 304	1.4301 / 304		
21	Sleeve	PVC	PVC		
	Type of valve	AF90D	AF94D	AF90D	AF94D
	Face to Face acc. DIN EN 558	Series 1	Series 27	Series 1	Series 27
	Weight	15.6 kg	14.2 kg	15.1 kg	13.9 kg

	Drawn	R. Zingg	01.02.16
	Checked	RIZ	01.02.16
	Item fig	AF90D AF94D PN16	DN 65
	Drawing no.	1602232.02	

	Druckprüfprotokoll 90D/94D Pressure test report 90D/94D	90D/94D
		FO_011.00 Seite: 1 von 1

Druckprüfprotokoll nach DIN EN 2266-1

Pressure test report acc. to DIN EN 12266-1

Unsere Auftrags-Nummer (our order number): 62017519 Position (item): 6

Artikel-Nummer (article number): 09065D.168T

Nenngrösse (DN) (nominal size) / Nenndruck (PN) (nominal pressure): **DN** 65 **PN** 16

Losgrösse (batch) Stk. (pcs): 1 pc

Charge Nr. der geprüften Kugelhähne
Melting-No. of tested Ball Valves

Nr./ no.	1	2
GT/ body	C8L237	
FT/ flange	C8L153	
	WCB	

Drehmoment an der Spindel (stem torque): **Manuell,** --- Nm
manually --- Nm

P10 / P11 (BA)

Prüfdruck (testing pressure): 24 bar (PN x 1.5)

Prüfzeit (testing time): 2 Min. (minutes)

P12 (BO)

Prüfdruck (testing pressure): 6 bar

Prüfzeit (testing time): 60 sec

	Ja / (yes)	Nein / (no)	Fehlermeldung (report of fault)
P10 / P11 (BA) Test bestanden (test fulfilled): Leckrate A	X		
P12 (BO) Test bestanden (test fulfilled): Leckrate A	X		

CE - Kennzeichnung (CE marking) DN32 - DN100

Los-Nr (batch number): **Quartal** ----- **Jahr (year)** ----- Beispiel: 1 / 10
(quarter) (year) Sample: 1 / 10

Die obengenannte(n) Armatur(n) wurde(n) in unserem Werk nach SN EN 12266- 1 mit dem aufgeführten Prüfdruck einer Druckprüfung unterzogen.

(Above mentioned ball valves have been tested in our factory acc. to SN EN 12266-1 to above listed pressure.)

Bemerkungen (Remarks): Tested without NPT 1/ 4"

Datum und Visum des Prüfers (Date and signature of tester): 10.02.2016 Richard Zingg

Erstellt: 13.09.2013 ROG	Freigabe: 25.09.2013 ROG	
Geändert:		