



JBT/JBTM Series Trunnion Ball Valve Manual For Soft-/ Metal-Seat DN50 ~ DN350



1. Please read this manual before installation or servicing.
2. Before installing or servicing, please ensure the line pressure has been relieved and any hazardous fluid has been drained or purged from the system.



1. Please do not use the valve exceeding its designed pressure range.
2. Please do not use the valve exceeding its designed temperature range.

INSTALLATION

1. Before installing, check all valves and mating flanges to ensure gasket surfaces are free from defects.
2. Make sure all valves and lines are clean without any dirt or debris, which may cause valve seats damaged.
3. Checking the piping is the alignment with appropriate supports. It is not recommended to install valves to improperly positioned pipes.
4. Valves can be installed for flow in either direction. Before installing, inspect the valve by visual for avoiding any damages.
5. Install the valve to the pipeline and tighten bolts properly. Notice that the over tightening of any side may cause the leakage.

OPERATION

1. Normally ball valve will be in close position when ex-factory.
2. Operate by handle. Rotate the handle in 90° (1/4 turn) counter-clockwise to open position. The handle should be parallel to the pipeline in open position or perpendicular to the pipeline when in close position.
3. Operate by gear. Turn the handwheel till the valve is fully opened.





JDV CONTROL VALVES CO., LTD.

A SPECIALIST IN DESIGN & MANUFACTURE OF VALVES

GENERAL MAINTENANCE

It is recommended to observe the valves periodically for ensuring the system under the proper performance.

1. After disassembling the valve body, it is recommended to replace new seals.
2. All bolts of valve body are tightened by pre-set torques with the even distribution around of the body, so any tightening or loosening of these bolts may cause the leakage from the body gasket.

When this occurs, replace the gasket and then tighten bolts with the proper torque.

Please refer parts drawing in <Figure 4> when disassembling or assembling.

DISASSEMBLY

1. Before disassembling, ensure the line pressure and dangerous media have been relieved.
2. Turn the valve to the close position.
3. Put the valve on clean platform by either side of flanged ends. (See Figure 1)
4. Loose cap bolts and nuts (10) from upper side.
5. Remove the cap (2) and body gasket (12). Take out the seat (11), seat ring seal (8), seat ring retainer (9), spring (21), seat ring O-Ring (19), and cap O-Ring (20). Be careful above parts may drop out when taking out from the cap.
6. Reverse valve by manual or crane. Put the valve on platform with proper and soft support to protect the ball from falling or damage. (See figure 2)
7. Repeat step. 4 ~ 5 to dismantle another cap and parts.

Figure 1

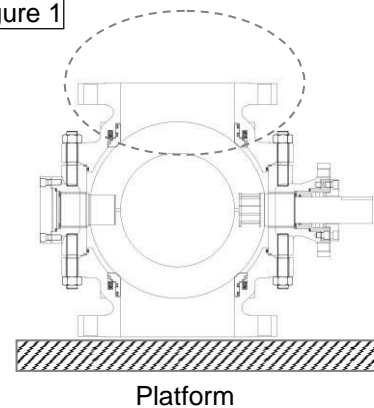
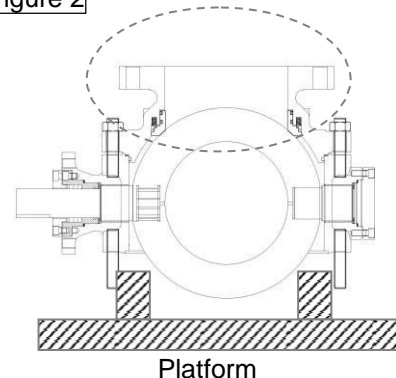

Figure 2



NO-2-2, LANE 292, SHIN NUNG RD., SHIN WU TOWN, TAOYUAN HSIEN, TAIWAN
TEL: 886-3-4203366 FAX: 886-3-4202268 E-mail: sales@jdv.com.tw Http://www.jdv.com.tw

6D-0539



JDV CONTROL VALVES CO., LTD.

A SPECIALIST IN DESIGN & MANUFACTURE OF VALVES

8. Turn the stem (4) by wrench to turn the ball in open position.

Get the valve body lain on platform and put a rope through the ball to lift slightly by the crane, so that the parts can be taken out easier. (See Figure 3)

9. Loose the retainer bolt (24), take out bearing retainer (7), trunnion stem gasket (23), and trunnion stem washer (22).

10. Loose gland bolts (26), take out gland (6).

11. Loose body gland bolts (26), take out body gland (5), gland packing (13), gland thrust washer (14), stem O-Ring (18), and stem thrust washer (16) from stem (4).

12. Remove stem (4) and trunnion stem (17).

13. Take out ball (3) and bearing (15).

14. Use a wire brush to clean the body, cap, ball, and other parts.

15. Remove the old or damaged seals carefully not to damage the parts.

Figure 3

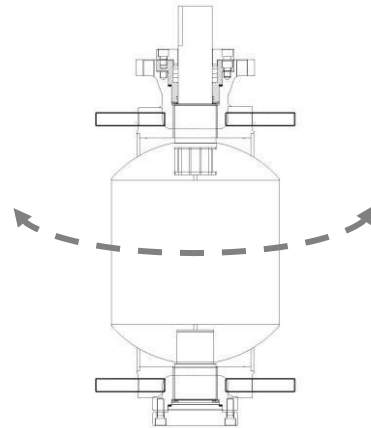

ASSEMBLY

1. Put the ball (3) into body (1) and insert bearing (15).

2. Insert stem (4) and trunnion stem (17).

3. Slip stem thrust washer (16), stem O-Ring (18), gland thrust washer (14), body gland (5), and packing (13) on the stem (4).

4. Tighten body gland bolts (25).

5. Slip gland (6) on stem (4) and tighten gland bolts (26).

6. Slip trunnion stem washer (22), trunnion stem gasket (23), and bearing retainer (7) on trunnion stem (17). Tighten retainer bolts (24).

7. Put cap O-Ring (20), seat ring O-Ring (19), spring (21), seat ring retainer (9), seat ring seal (8) and seat (11) into each cap (2).

8. Put body gaskets (12) on the joint between body (1) and caps (2).



NO-2-2, LANE 292, SHIN NUNG RD., SHIN WU TOWN, TAOYUAN HSIEN, TAIWAN
TEL: 886-3-4203366 FAX: 886-3-4202268 E-mail: sales@jdv.com.tw Http://www.jdv.com.tw



JDV CONTROL VALVES CO., LTD.

A SPECIALIST IN DESIGN & MANUFACTURE OF VALVES

9. Put caps (2) on body (1) joint. Tighten bolts & nuts (10). Be careful not to drop out the seals and seats from caps.

10. Water pressure test to shell leakage no less than 1.5 times of valve rating and seat leakage no less than 1.1 times of valve rating.

TROUBLE SHOOTING

Area	Description	Solution
Inner	Leakage from upstream bore	1. Turn the valve to half open position to check if there is any damage on the touched surface of ball (3) and seats (11).
		2. If no, replace seat ring seal (8) and body gasket (12).
Outer	Leakage from stem	3. If yes, replace damaged ball (3) or seat (11), seat ring seal (8) and body gasket (12).
		4. Body gasket (12) is necessary to be replaced in every disassembling.
	Leakage from bottom	1. Tighten body gland bolts & nuts (25).
Leakage from the joint between body and cap.	Leakage from the joint between body and cap.	2. If step 1 cannot stop leakage, disassemble valve to replace gland packing (13) and gland thrust washer (14).
		3. Body gasket (12) is necessary to be replaced every disassembling.
Leakage from the joint between body and cap.	Leakage from the joint between body and cap.	4. Tighten joint bolts & nuts (10).
		2. If step 1 cannot stop leakage, disassemble body (1) and cap (2) to replace body gasket (12).



NO-2-2, LANE 292, SHIN NUNG RD., SHIN WU TOWN, TAOYUAN HSIEN, TAIWAN
 TEL: 886-3-4203366 FAX: 886-3-4202268 E-mail: sales@jdv.com.tw Http://www.jdv.com.tw

6D-0539



JDV CONTROL VALVES CO., LTD.

A SPECIALIST IN DESIGN & MANUFACTURE OF VALVES

Figure 4

DN50~DN350 (2" ~14")

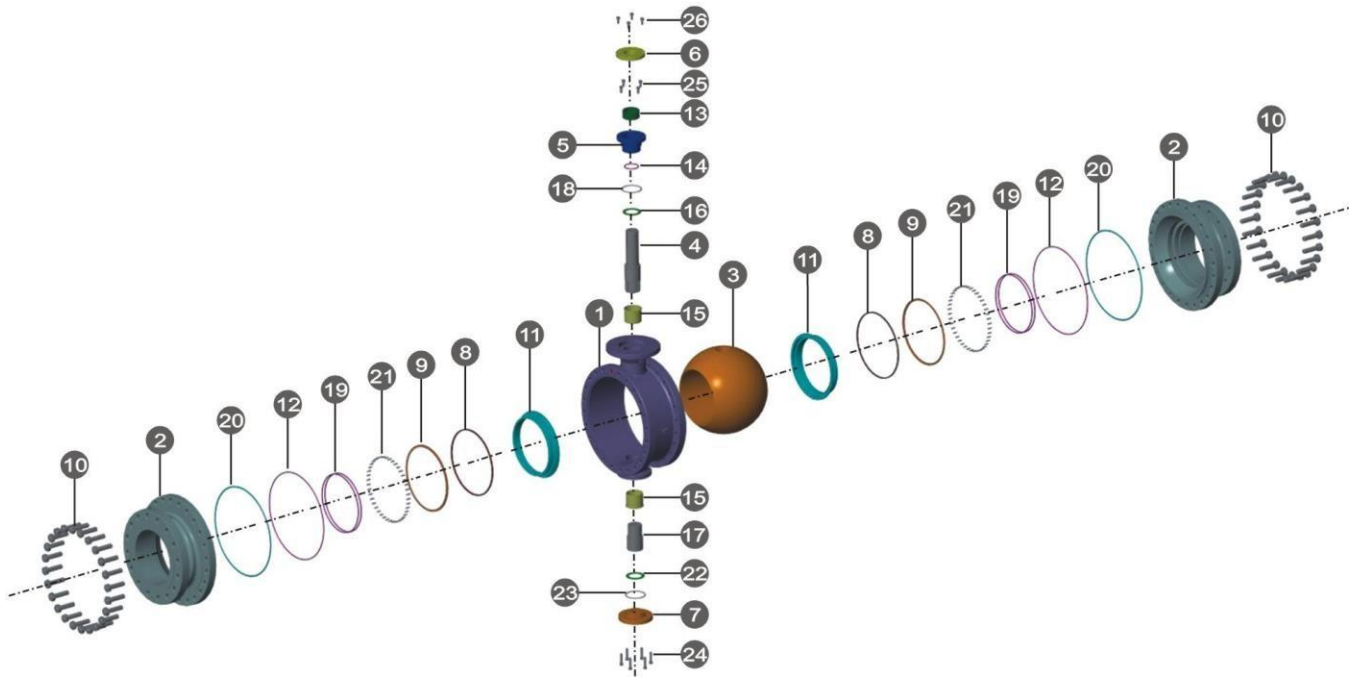

NO.	PART NAME	NO.	PART NAME	NO.	PART NAME
1	BODY	10	BOLT&NUT	19	SEAT RING O-RING
2	CAP	11	SEAT	20	CAP O-RING
3	BALL	12	BODY GASKET	21	SPRING
4	STEM	13	GLAND PACKING	22	TRUNNION STEM WASHER
5	BODY GLAND	14	GLAND THRUST WASHER	23	TRUNNION STEM GASKET
6	GLAND	15	BEARING	24	RETAINER BOLT
7	BEARING RETAINER	16	STEM THRUST WASHER	25	BODY GLAND BOLT
8	SEAT RING SEAL	17	TRUNNION STEM	26	GLAND BOLT
9	SEAT RING RETAINER	18	STEM O-RING	27	



NO-2-2, LANE 292, SHIN NUNG RD., SHIN WU TOWN, TAOYUAN HSIEN, TAIWAN
 TEL: 886-3-4203366 FAX: 886-3-4202268 E-mail: sales@jdv.com.tw Http://www.jdv.com.tw

6D-0539